

TS-250
Rev. D
Refined Fuels PD Meters
Size 2" Type 4-MT & 4D-MT

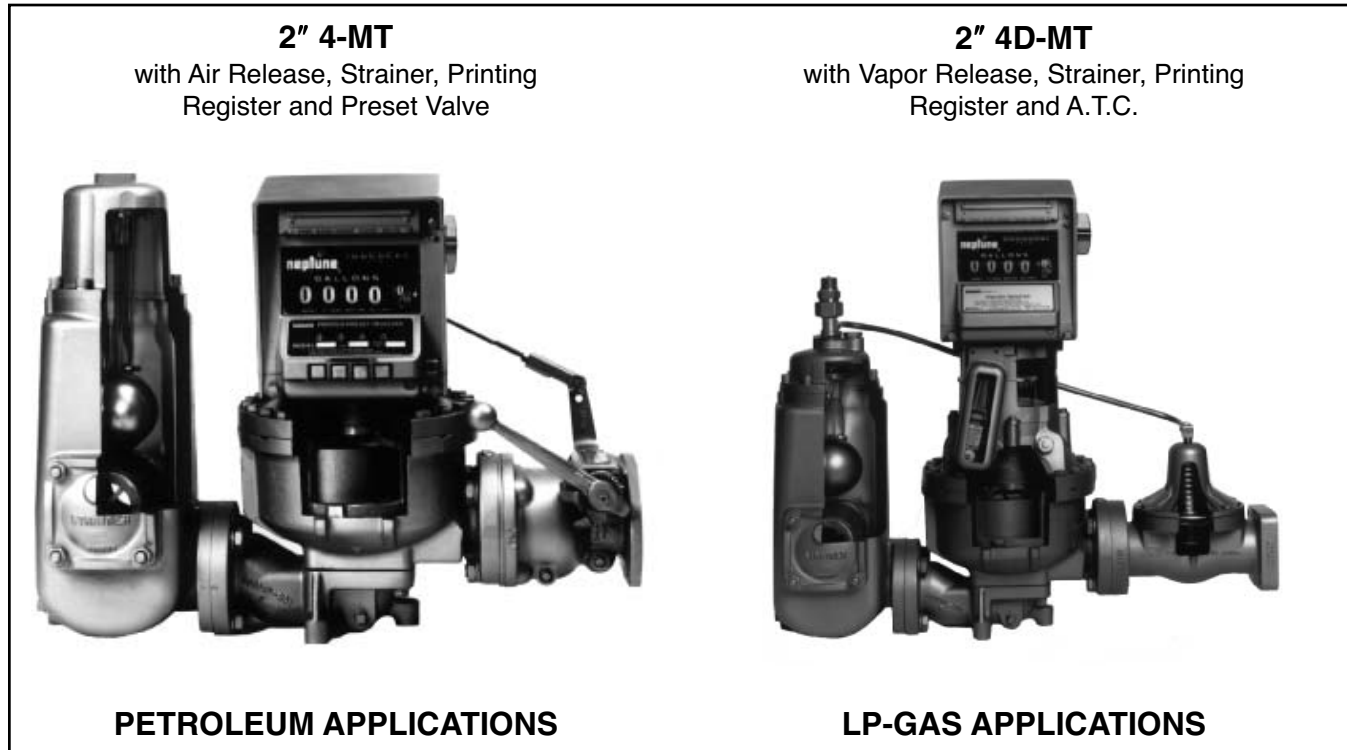

2" PETROLEUM AND LP-GAS TANK TRUCK METERS



ISO 9001 Certified Manufacturing Facility

DESCRIPTION

Actaris 2" Refined Fuels Meters are an excellent choice for truck mounted metering. These 2" aluminum body flowmeters come complete and ready for installation and are ideal for both single meter and multi-meter applications.

The 2" Type 4-MT meter for petroleum products includes a new model air release that provides greater split compartment testing performance than previous models. The Air Release includes a fully adjustable float linkage for fine turning the Air Release for various conditions. The float can be raised or lowered to increase or decrease the sensitivity of the unit. The 2" Type 4-MT meter is designed for use with a variety of petroleum based products such as Fuel Oil, Diesel Fuel, Gasoline, Kerosene and Lube Oil.

The 2" Type 4D-MT meter for Liquefied Propane Gas features a flanged outlet with ductile iron companion

flange for easy installation and removal. The 2" Type 4D-MT boasts a 33% weight reduction compared to the old 2" Type 4D.

Both the 2" Type 4-MT and the 2" Type 4D-MT meters are backed by Actaris's 3 year/3,000,000 gallon measuring chamber limited warranty.

DESIGN FEATURES

With their low pressure drop and high accuracy, these meters are ideally suited for custody transfer applications. Each meter is certified by the National Institute of Standards and Technology for conformance under the National Type Evaluation Program and complies with the applicable technical requirements of Handbook 44 for Weighing and Measuring Devices. Easily assembled and installed for either right hand, left hand or angle flow, these meters will fit practically any piping and space condition.

SPECIFICATIONS	2" TYPE 4-MT (PETROLEUM)	2" TYPE 4D-MT (LP-GAS)
FLOW RATE	20 to 150 gpm (76 to 570 lpm)	20 to 100 gpm (76 to 380 lpm)
TEMPERATURE (OPERATIONAL)	-23°C to 52°C (-10°F to 125°F)	-23°C to 52°C (-10°F to 125°F)
WORKING PRESSURE	150 psi (10 bar) max. (10.6 kg/cm ²)	350 psi (24 bar) max. (24.6 kg/cm ²)
INLET CONNECTION	Companion Flange tapped 2" NPT	Inlet Check Valve with 2" NPT
OUTLET CONNECTION	2" ANSI Type Flange	Companion Flange tapped for 1½ or 2" NPT
CALIBRATION	Neptune positive drive change gears and patented gear shifter assembly.	Neptune positive drive change gears and patented gear shifter assembly.
UNITS OF MEASURE	U.S. Gallons, Imperial Gallons or Litres	U.S. Gallons, Imperial Gallons or Litres
RESET WHEEL CAPACITY	9,999.9 gallons (99999 litres)	9,999.9 gallons (99999 litres)
PRESET SETTING CAPACITY	9,999 gallons (9990 litres)	Not Applicable
PRINTING WHEEL CAPACITY	9,999.9 gallons (99990 litres)	9,999.9 gallons (99990 litres)
TOTALIZER CAPACITY	99,999,999 gallons (99,999,990 litres)	99,999,999 gallons (99,999,990 litres)
TEMPERATURE COMPENSATOR	Available with E4000 Electronic Register	Range -23°C to 52°C (-10°F to 125°F) Compensates to 15°C (60°F)
MATERIALS		
STRAINER	40 mesh stainless steel	80 mesh stainless steel
HOUSING	Aluminum	Aluminum
MEASURING CHAMBER	Bronze	Bronze
PISTON	Nituff® Teflon® Impregnation Coating ^①	Nituff® Teflon® Impregnation Coating [□]
DYNAMIC SEALS	Viton	Buna N
STATIC SEALS	Buna N	Buna N
APPROVALS		
SAFETY		UL
CUSTODY TRANSFER	N.I.S.T./N.T.E.P. Handbook 44 C#02-046	N.I.S.T./N.T.E.P. Handbook 44 C#02-047

ACCESSORIES

MECHANICAL REGISTERS, Model 800

- **831/841:** Direct reading register with 5 digit reset and 8 digit non-resettable totalizer.
- **832/842:** Direct read, plus preset (predetermined delivery quantity) when used with a 2-stage valve (preset available only with Type 4-MT).
- **833/843:** Direct read with a 5 digit print out, face up ticket and zero start and final delivery.
- **834/844:** (2" Type 4-MT Petroleum only) Direct read with both preset and ticket printer and two stage shut-off.

For additional data, refer to TS-301 or contact sales.

ELECTRONIC REGISTERS

- **E4000:** Neptune® E4000 Electronic Register. For more detailed information, request form TS-303.

MECHANICAL PRESET VALVES

Neptune Auto-Stop 2-stage valves are available for 2" Type 4-MT Petroleum flowmeters. Installed in accordance with the appropriate Operating & Maintenance Manual, they meet N.I.S.T. parameters.

The 2-stage double trip valve minimizes the impact of

hydraulic shock on both the dispensing lines and the meter unit itself that may result from either high operating pressures or high flow rates (over 50 GPM/190 LPM). The operation of the 2-stage valve is simple and reliable.

DIFFERENTIAL AIR-CONTROL VALVE

The Differential Air-Control Valve (DACV) is a high performance air elimination system that works with the air release of a 2" Type 4-MT Petroleum meter to substantially reduce measured air through the meter, and also reduce spitting. The DACV is designed to meet air elimination challenges presented when delivering from multiple compartments via common manifolds and high capacity pumps. Small accumulations, or large slugs of air, cause the flow to be shut off, preventing incorrect measurement. After the air has been vented and liquid supply restored, the flow automatically resumes.

ADJUSTABLE BACK PRESSURE VALVE

Neptune offers an adjustable two position (7.5 PSI cracking (standard) or 15 PSI cracking) back pressure valve for the 2" Type 4-MT Petroleum Meter. The compact valve which fits between the connector and maincase adds only ¼" to the height of the meter. The valve is used to add back pressure to the meter to increase air elimination for systems with excess air present.

^① Coatings may be similar material with the same performance criteria.

ACCURACY CURVE* 2" TYPE 4-MT & 4D-MT**

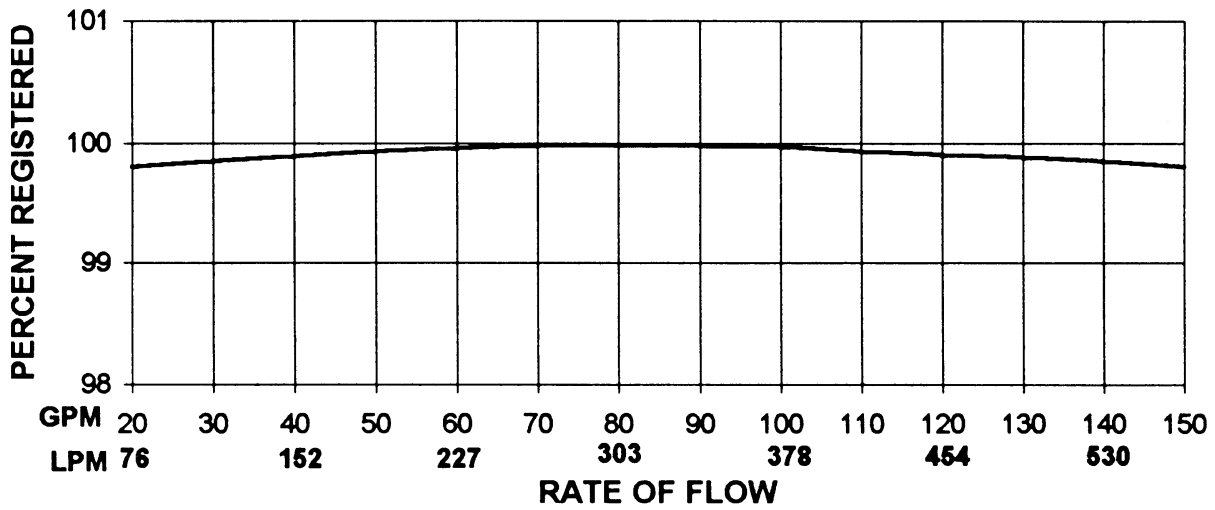

*Tested with Varnolene at 60° F. **Type 4D-MT rated to 100 GPM only.

PRESSURE DROP* 2" TYPE 4-MT (PETROLEUM) w/o Optional Back Pressure Valve

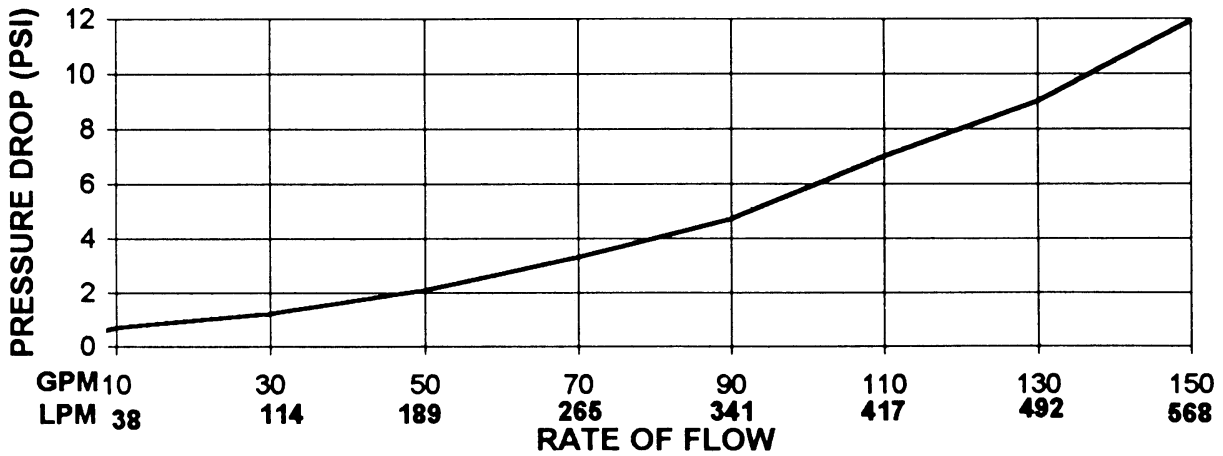

TICKET DIMENSIONS

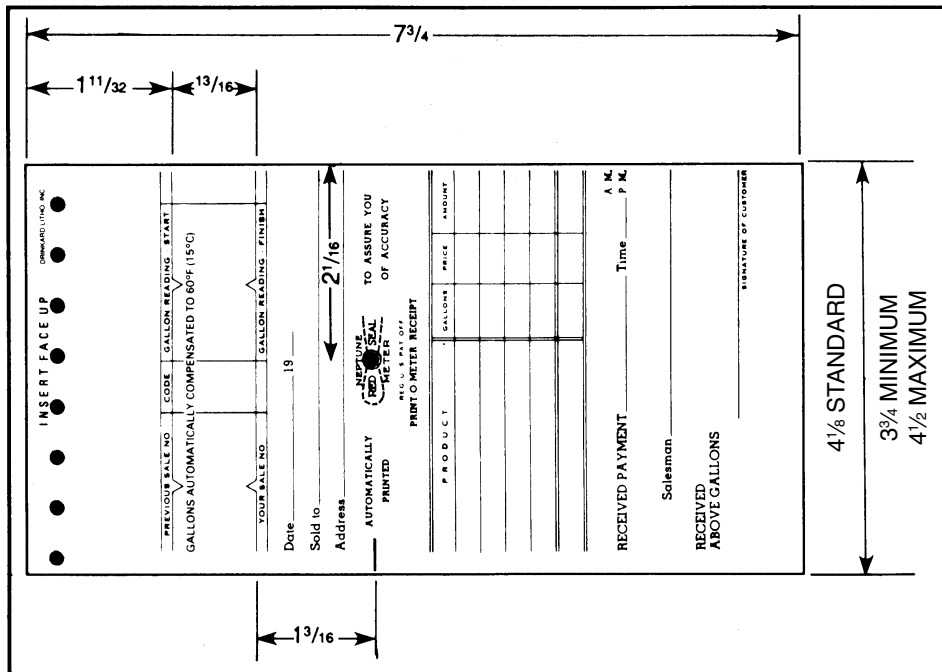

DIMENSIONAL DATA

2" 4-MT

PETROLEUM APPLICATIONS

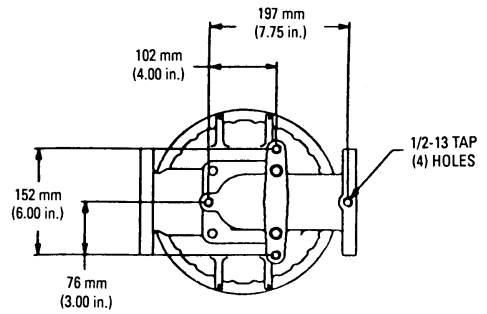
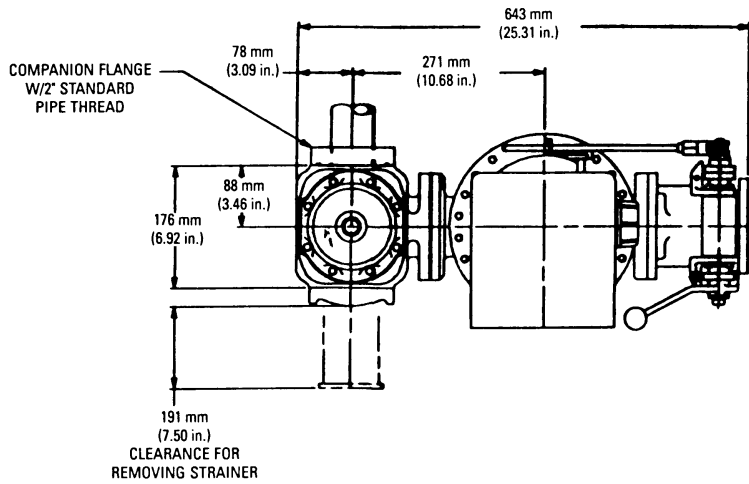

BOTTOM VIEW

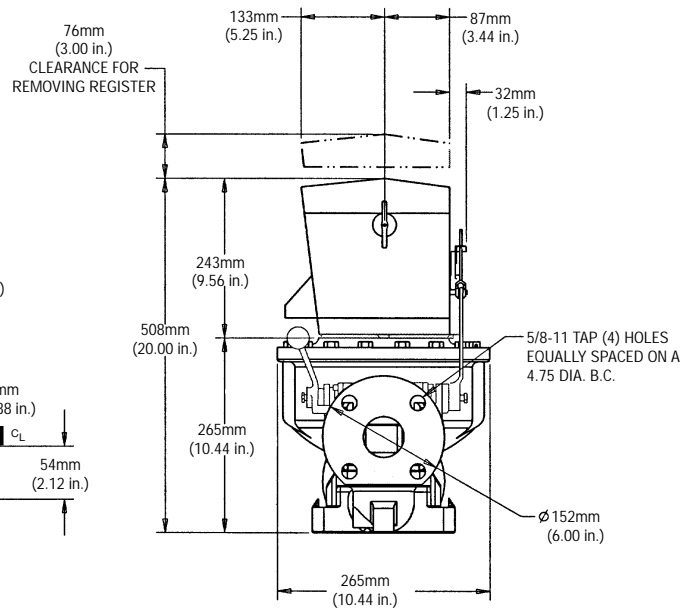
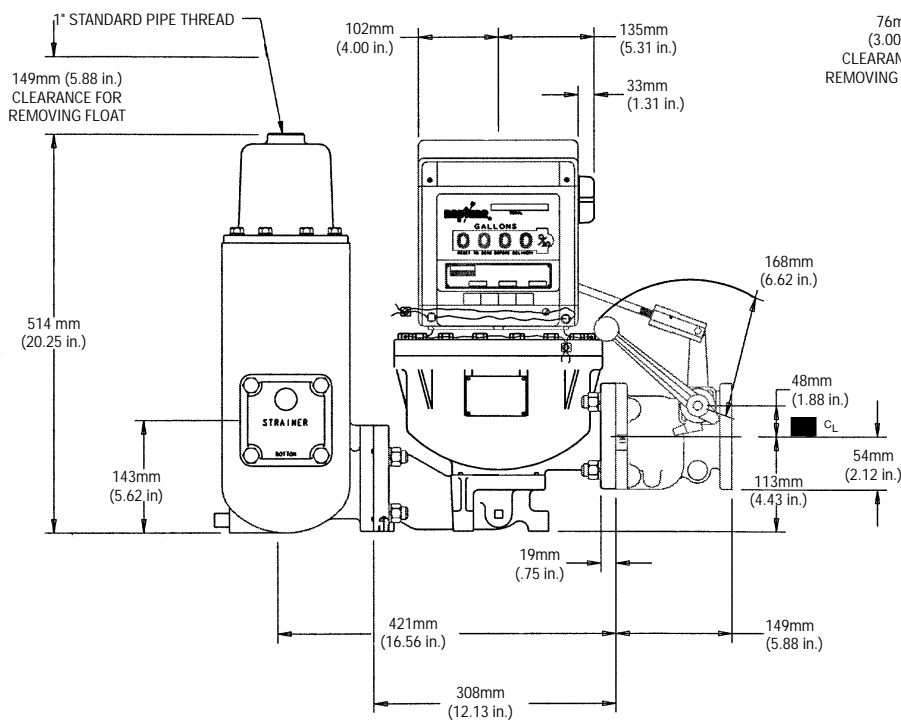

C_L — Means Center Line

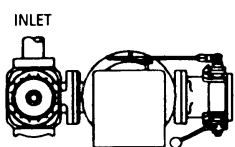

RIGHT-HAND ASSEMBLY (STANDARD)

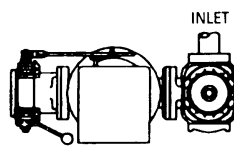

LEFT-HAND ASSEMBLY

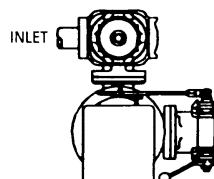

ANGLE ASSEMBLY (RIGHT-HAND)

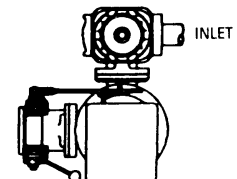

ANGLE ASSEMBLY (LEFT-HAND)

DIMENSIONAL DATA 2" 4D-MT LP-GAS APPLICATIONS

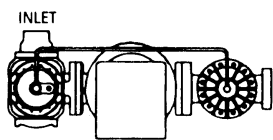
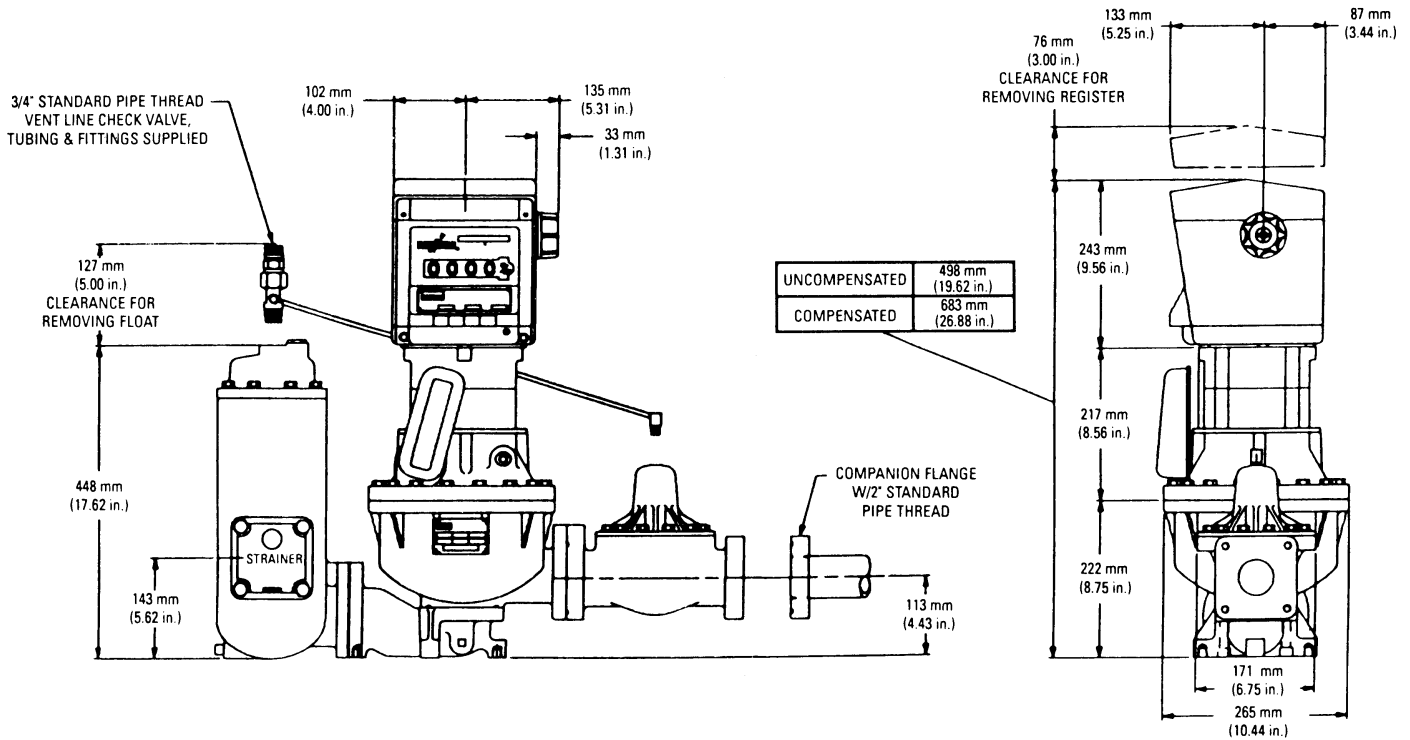
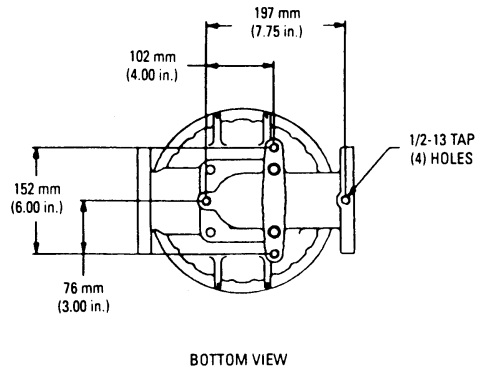
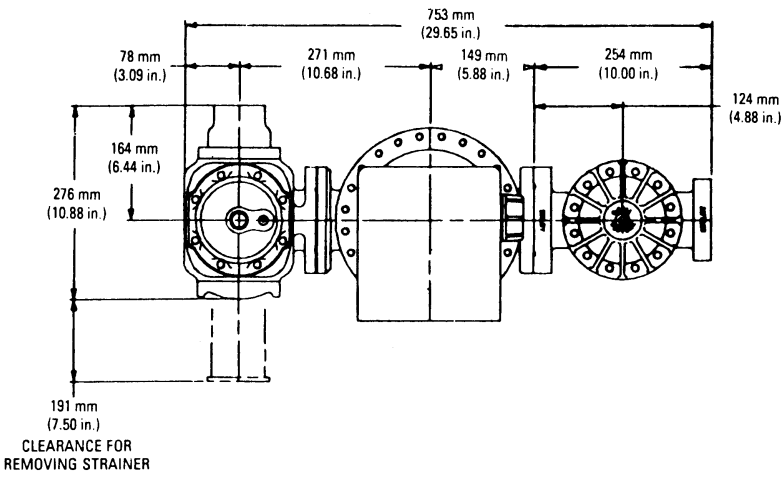

RIGHT-HAND ASSEMBLY (STANDARD)

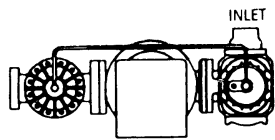

LEFT-HAND ASSEMBLY

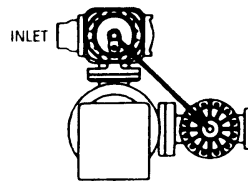

ANGLE ASSEMBLY (RIGHT-HAND)

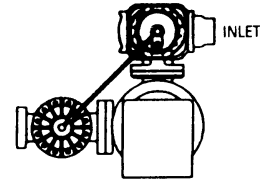

ANGLE ASSEMBLY (LEFT-HAND)

