

PowerDry

Mid-range Container Dryer

Secomak
a i r a t w o r k

T: +44 (0) 20 8732 1300

E: sales@secomak.com

For medium & budget operations up to 60,000 containers per hour

POWERDRY is a range of drying systems designed to fit over a clients own conveyor and guide system.

Available in a variety of standard configurations to suit the major drying problems in the food and beverage industries at the competitive prices demanded by the worlds major OEMs and machine integrators.

Manufactured from high grade stainless steel, the top enclosure, with space saving gull wing doors, houses a range of drying fixtures in set configurations for all major drying tasks.

The dispersed water is contained and directed to ground level via an integral drip tray and drain which also serves to isolate and protect the high efficiency blower.

There are a choice of power packs from the **Secomak** range of high velocity blowers fitted with high efficiency motors and drives.

Incremental scales for all diameter and height changes come as standard, as well as special acoustic packs to reduce noise to legislative levels.

POWERDRY offers high performance, ease-of-use and reliability at competitive prices with **Secomak** backup and technical support.

*Model illustrated is 15kW PowerDry with optional isolator



POWERDRY SPECIFIC FEATURES

HIGH PERFORMANCE DRYING

A RANGE OF STANDARD CONFIGURATIONS

INCREMENTAL SCALES FOR EASY ADJUSTMENT

CHOICE OF POWER PACKS

STAINLESS CONSTRUCTION

LOWE NOISE EMISSIONS

SMALL FOOT PRINT

HIGH RELIABILITY

BACKED BY SECOMAK SUPPORT

For further information please contact Secomak on +44 (0) 20 8732 1300 or sales@secomak.com

www.secomak-solutions.com

Secomak Ltd.

330 Centennial Park, Elstree, Hertfordshire, WD6 3TJ, UK.

Telephone: +44 (0) 20 8732 1300 Fax: +44 (0) 20 8732 1301

Email: sales@secomak.com Web: www.secomak-solutions.com

PowerDry

Mid-range Container Dryer

SECOMAK
air at work

T: +44 (0) 20 8732 1300

E: sales@secomak.com

POWERDRY STANDARD CONFIGURATIONS

Beverage Can	Glass Bottle	PET Bottle
Date coding Drying can tops Drying for final pack Drying for can labels	Date coding Labelling Cap inspection Shrink sleeves Returnable inspection Full bottle inspection	Date coding Labelling Cap inspection Camera orientation
24,000 - 60,000 cans per hour	12,000 - 60,000 bottles per hour	12,000 - 48,000 bottles per hour

POWERDRY OPTIONS

Blower Configurations	Noise Control & Processing	Additional Options
4kW	Additional acoustic packs	Controls
8kW	Guide rails	Spares packs
15 kW	Conveyors	Extended warranties

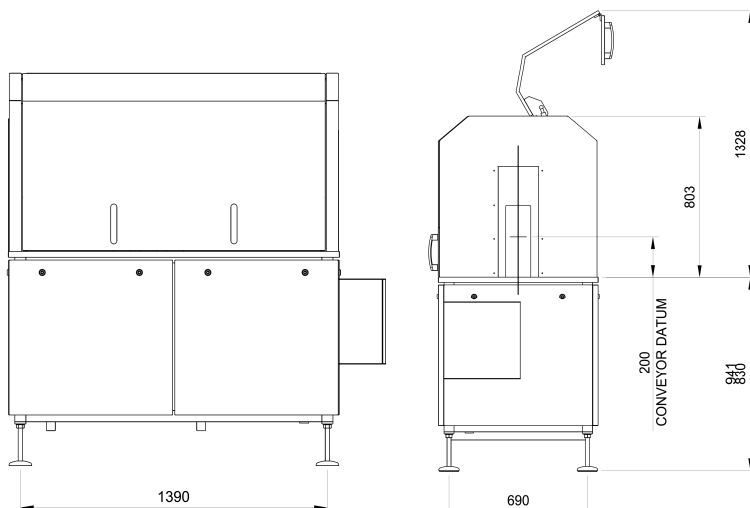

Dimensions

Length	Width	Gross Weight
1500mm	800mm	550kg

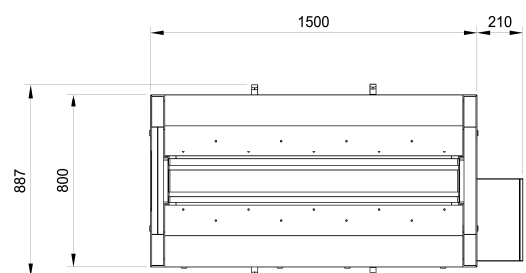

For further information please contact Secomak on +44 (0) 20 8732 1300 or sales@secomak.com

www.secomak-solutions.com

Secomak Ltd.

330 Centennial Park, Elstree, Hertfordshire, WD6 3TJ, UK.

Telephone: +44 (0) 20 8732 1300 Fax: +44 (0) 20 8732 1301

Email: sales@secomak.com Web: www.secomak-solutions.com