



HydraFLOW

50 gpm max.

3000 psi max



WARNING

DO NOT OPERATE
BEFORE READING

INSTALLATION, OPERATION AND
MAINTENANCE

MANUAL

Rev 4 February, 2014

Copyright © Paragon Tank Truck Equipment LLC



- SAFETY INSTRUCTIONS**
1. Do not operate before reading the enclosed instruction manual.
 2. Use adequate protection, warning and safety equipment necessary to protect against hazards involved in installation and

<p>ADVERTENCIA</p> <p>PRESIÓN ALTA DE ACEITE. Puede causar lesiones graves. Desconectar la energía, bajar la carga y descargar la presión antes de dar servicio al sistema hidráulico.</p>		<p>WARNING</p> <p>HIGH PRESSURE OIL. May cause severe injury. Disconnect power, lower load and relieve pressure before servicing hydraulic system.</p>
--	--	--

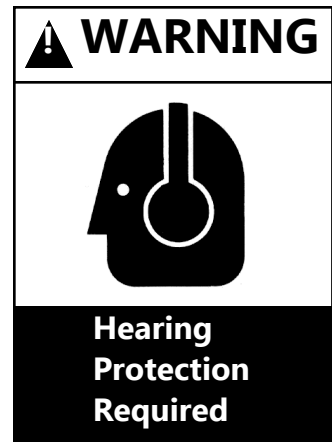

NOTICE

Safety instruction tags were attached to your unit prior to shipment. Do not remove, paint over or obscure in any manner.

Failure to heed these warnings could result in serious bodily injury to the personnel operating and maintaining this equipment.

TABLE OF CONTENTS

SECTION	PAGE
SAFETY INSTRUCTIONS & WARNING TAGS	2
SAFETY PRECAUTIONS	3
INTRODUCTION	4
START-UP, OPERATION & MAINTENANCE	5
OUTLINE DRAWING	7
PARTS LIST	9
WARRANTY	10

SAFETY PRECAUTIONS

For equipment covered specifically or indirectly in this instruction book, it is important that all personnel observe safety precautions to minimize the chances of injury. Among many considerations, the following should particularly be noted:

- Rotating shafts can be dangerous. You can snag clothes, skin, hair, hands, etc. This can cause serious injury or death.
- Do not work under the vehicle when the engine is running.
- Do not work on the hydraulic system with engine running or power take off engaged.
- Do not engage or disengage driven equipment by hand from under the vehicle when the engine is running.
- If power take off and/or shaft are still exposed after installation, install a guard.
- Install a support strap when servicing a drive shaft to prevent personal injury.
- Always use hose rated for hydraulic duty and at the correct pressure.
- A serious or fatal injury can occur . . .
 - ⇒ if you lack proper training
 - ⇒ if you fail to follow proper procedures
 - ⇒ if you do not use proper tools and safety equipment
 - ⇒ if you assemble hydraulic system components improperly
 - ⇒ if you use incompatible drive line components
 - ⇒ if you use worn-out or damaged drive line components
 - ⇒ if you use drive line components in a non-approved application.
- This manual contains safety instructions. Read, understand and follow this manual.
 - ⇒ Get proper training
 - ⇒ Learn and follow safe operating procedures
 - ⇒ Use proper tools and safety equipment



(800) 471-8769

INTRODUCTION

CONGRATULATIONS on your purchase of a new Hydraflow. Please examine the unit for shipping damage, and **if any damage is found, report it immediately to the carrier.** If unit is to be installed at a later date make sure it is stored in a clean, dry location.



Warning: Serious injury can result from operating or repairing the unit without reading the service manual and taking adequate safety precautions.

Installation

Power Take off & Hydraulic Pump

- Mount power take off, and brace hydraulic pump per manufacturers instructions.
- Ensure that the female spline of the power take off is filled with grease.
- Mount hydraulic pump to P.T.O. using the fasteners supplied by the manufacturer.

Note:

Please refer to your hydraulic pump installation manual for correct filtration and suction specifications. The standard filter supplied in the HydraFlow is a 10 micron nominal suitable for gear equipment. Contact factory for other filtration media.

Note:

To avoid premature spline wear of the pump and PTO from torsional vibration, contact the engine manufacturer for the proper engine speed that will reduces torsional vibration to a minimum based on application.

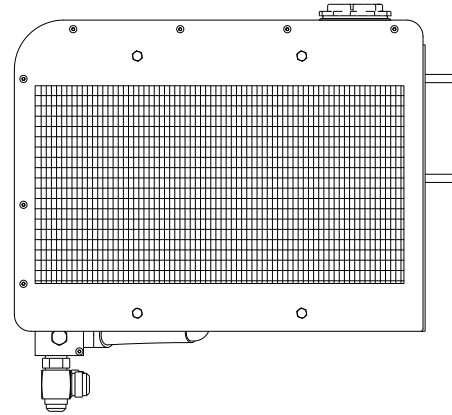

Mounting Hydraflow

- Drill 21/32" diameter holes as shown on page 7.
- Use the cap screws, washers, and nuts supplied to mount the Hydraflow.

Hydraulic Hoses & Fittings.

- Do not use thread tape or pipe dope on threaded connection. This will contaminate the hydraulic system.
- All hoses are customer supplied. Fit all hoses according to system drawings.
- High pressure hoses must have a pressure rating equal or higher than the hydraulic system relief valve setting.
- The suction hose must be capable of operating in 28" Hg vacuum service.
- Attach gasket to four bolt flange before installing the suction connection (when applicable).

SUCTION HOSE CHART

GPM FLOW	HOSE SIZE
0-20	1-1/4"
20-25	1-1/2"
26-50	2"



(800) 471-8769

Preferred behind the cab mount (optimum suction conditions)

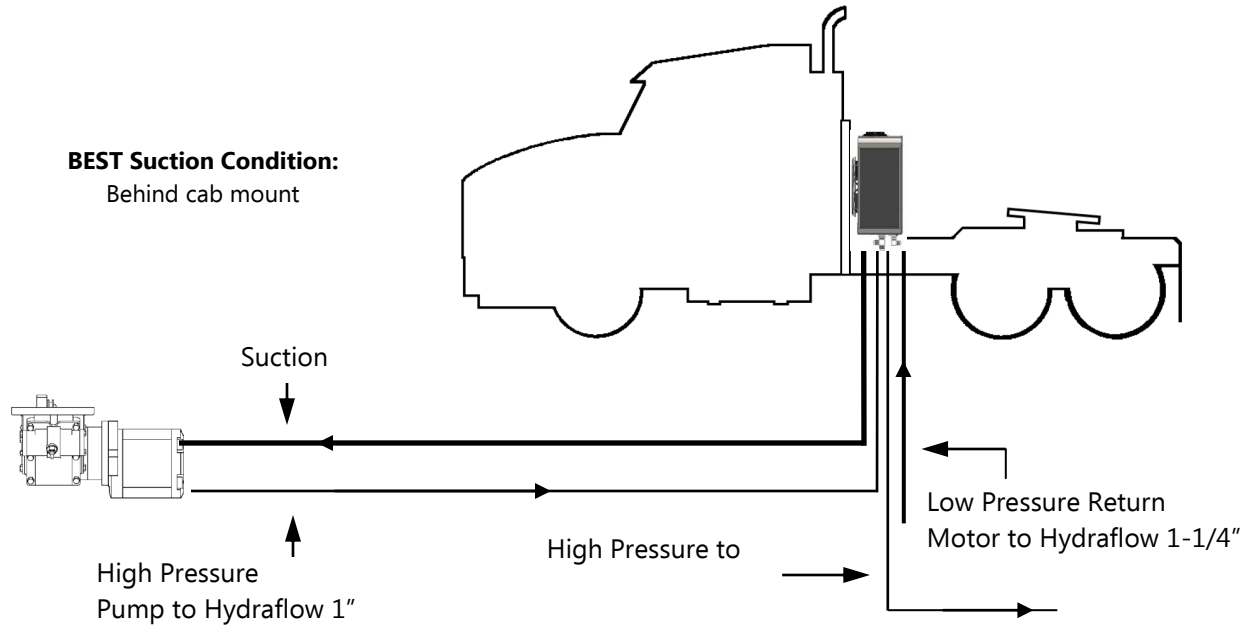

Note:

- *Review Hose Chart on page 4 to insure the correct suction hose sizing.*
- *For off road applications do not mount Hydraflow directly to the frame rail.*
- *See system circuit drawing for complete hydraulic plumbing.*

Alternate Frame Rail Mount

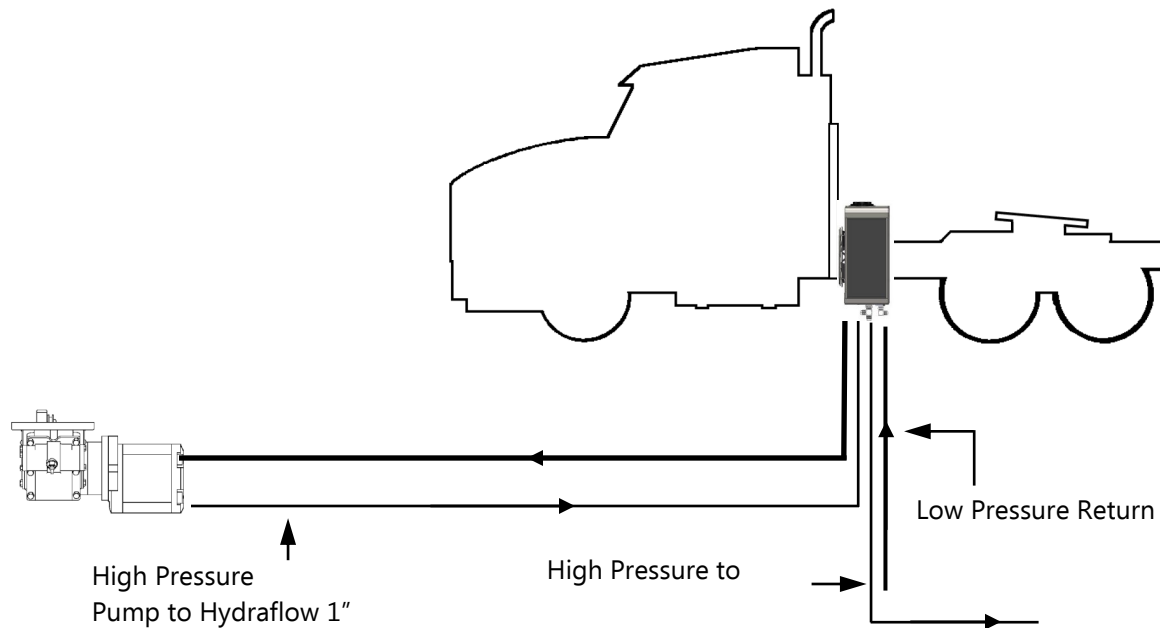

Initial Start Up (Two People are Required).

1. Remove filler cap, filter and filter bowl.
2. Fill Hydraflow **1/2 full** with hydraulic lubricant.

Note:

- a. Paragon recommends an (ISO) 32 no-foaming hydraulic oil.
(Example: Shell Tellus T32 Hydraulic Oil)**
- b. Use a paint filter as a strainer while filling.**

2. Replace fill cap.
3. Check all hoses and connections for leaks.
4. Start engine and **slowly** release the clutch, engage the PTO and pump.
5. Run for 5 minutes to eliminate air from the system.
6. Disengage PTO, stop engine.
7. Remove fill cap and fill to the **bottom** of the sight glass. Replace filter bowl, filter, and fill cap
8. Start engine and slowly release the clutch, while engine is running engage the PTO and pump.
9. Check for leaks, disengage PTO and stop engine.

Operation of System.

1. Check oil level in the Hydraflow. Proper oil level is at the bottom of the sight glass when the unit is not operating.
2. Check fan and radiator for air flow. Clean or clear of any obstruction as needed.
3. Ensure parking brake is applied, control valves are in the neutral position.
4. Engage PTO per manufactures instructions.

Note:

- **Oil level may drop if air is trapped in the system. Shut down the system and fill oil tank to the bottom of the sight glass.**

Daily Check oil level before operating (the system must be off). Correct level is to the bottom of the sight glass when not operating

Weekly Visually inspect the system each week. Check hoses, fittings and mounting.

Every 3 months Change filter every 3 months.
Grease PTO / Pump spline every 3 months.

Every 6 months Change oil and filter every 6 months.

5. Operate valves slowly.
6. To shut down system follow steps 5 thru 3 in reverse.



(800) 471-8769

Overall Dimensions

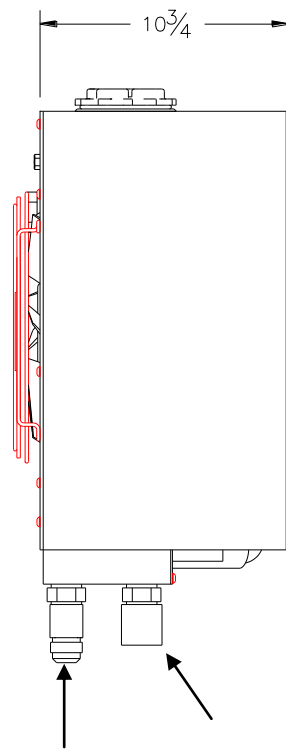
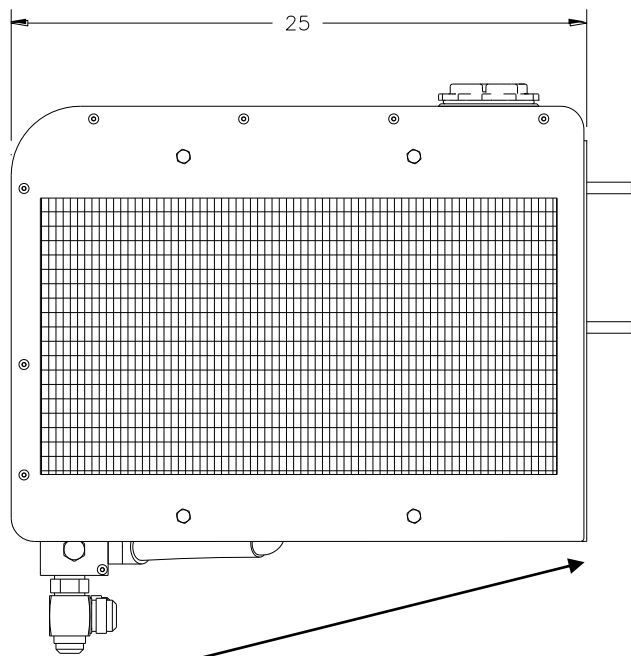
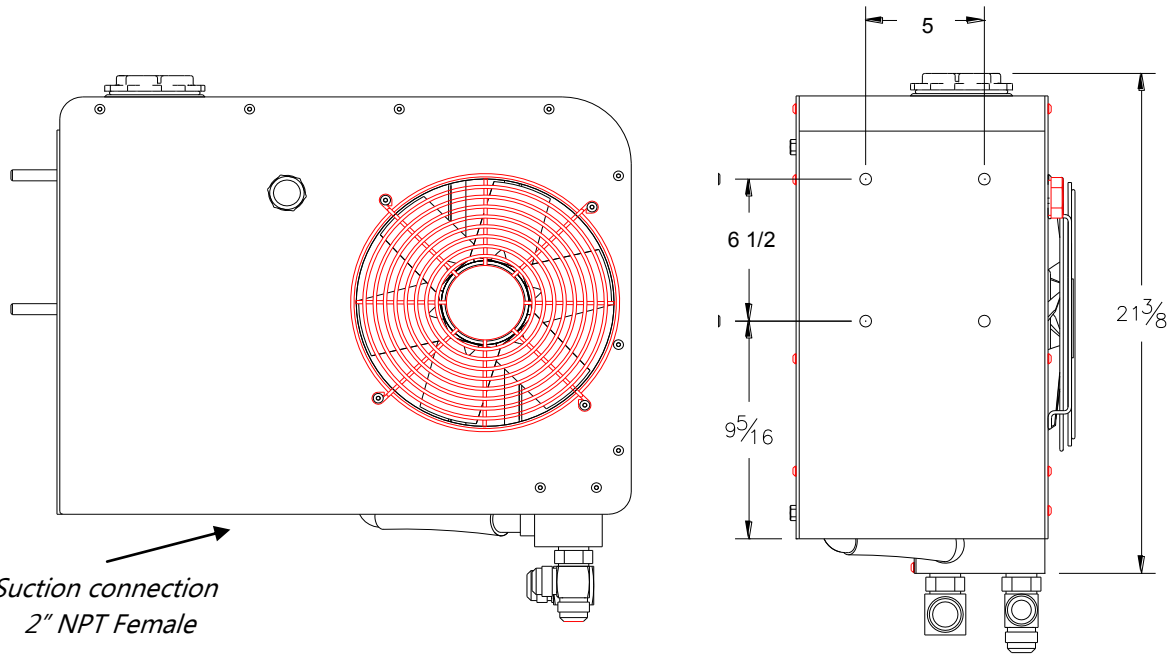

Note:

- Provide adequate support for hoses at this location.
- Do not let hoses hang loose, premature

HP connections 1" JIC Male (in/out) Return connection

PARTS LIST

Part Number	DESCRIPTION	QTY
322-026	Fan Motor Flow Control	1.00
300-001	Fan Motor - HD Hydraflow	1.00
228-010	Screw Hex Head GR5 5/16" x 1" PLTD	4.00
85234	Nut 5/16" plated	4.00
90191-0313	Washer Lock 5/16" plated	4.00
85219	Hose barb 90 elbow -8 barb x -8 nptm plated	1.00
328-000	Hose barb 45 elbow -8 barb x -6 SAE	1.00
85236	Hose - fan motor return 1/2" (specifiy length)	n/a
361-000	Hose - fan motor feed 3500 psi - 10-1/4" long	1.00
85237	Hose clamps 1/2" hose Heavy Duty	2.00
85258	E clip 1/2"	2.00
335-001	Low pressure bypass valve	1.00
328-003	Elbow -12 barb x -12 NPTM	1.00
85242-1	Hose - low pressure bypass (specify length)	n/a
362-001	Control Block - HD series	1.00
362-003	Control Block - HD series (RDFA)	1.00
331-000	Relief Valve - 3000 psi	1.00
331-001	Relief Valve - 3000 psi (RDFA)	1.00
322-015	Elbow 90 degree -16 SAE x -20 JIC	1.00
320-015	Tee -16SAE x -16 JIC x -16 JIC	1.00
328-001	Elbow 45deg -16SAE x -16 Barb	1.00
85229	Elbow 90 deg - SAE -16 x 1" barb	1.00
352-001	Filter/diffuser - 4 bolt	1.00
350-000	Filter element - HD Hydraflow	1.00
359-002	Breather - Red Cap	1.00
85234	Nut - 5/16"	4.00
92354-0313	Washer - lock 5/16 s/s	4.00
370-000	Radiator	1.00
228-010	Screw 15/16" x 1" Button Head S/S	4.00
92354-0313	Washer - lock 5/16" s/s	4.00
85234	Nut - 5/16"	4.00
85242-1	Hose - Rad bypass - 3/4" (specify length)	n/a
85245	Hose clamps 3/4"	2.00
85244	Hose - Rad in 1" (specify length)	n/a
85244	Hose - Rad out 1" (specify length)	n/a
85233	Hose clamps 1"	8.00
335-002	Radiator bypass valve	1.00
85227	Barb to check valve 3/4" hose barb x 3/4" nptm	1.00
507-000	Fan	1.00
524-000	Fan guard	1.00
85230	Screw 1/4-20 x 3/4" Button head allen s/s	18.00
355-003	Sight glass	1.00
93241-0503	1/2" npt plug	1.00



WARRANTY – HYDRAFLOW

Subject to the terms and conditions hereinafter set forth and set forth in General Terms of Sale, Paragon Tank Truck Equipment LLC (the seller) warrants products and parts of its manufacture, when shipped, will be of good quality and will be free from defects in material and workmanship. This warranty applies only to Seller's equipment, under use and service in accordance with seller's written instructions, recommendations and ratings for installation, operating, maintenance and service of products, for a period as stated in the table below.

THIS WARRANTY EXTENDS ONLY TO BUYER AND/OR ORIGINAL END USER, AND IN NO EVENT SHALL THE SELLER BE LIABLE FOR PROPERTY DAMAGE SUSTAINED BY A PERSON DESIGNATED BY THE LAW OF ANY JURISDICTION AS A THIRD PARTY BENEFICIARY OF THIS WARRANTY OR ANY OTHER WARRANTY HELD TO SURVIVE SELLER'S DISCLAIMER.

Product Type	Warranty Duration
New	18 months from date of shipment, or 12 months after initial startup date, whichever occurs first

All accessories furnished by Seller but manufactured by others bear only that manufacturer's standard warranty.

All claims for defective products, parts, or work under this warranty must be made in writing immediately upon discovery and, in any event within one (1) year from date of shipment of the applicable item and all claims for defective work must be made in writing immediately upon discovery and in any event within one (1) year from date of completion thereof by Seller. Unless done with prior written consent of Seller, any repairs, alterations or disassembly of Seller's equipment shall void warranty. Installation and transportation costs are not included and defective items must be held for Seller's inspection and returned to Seller's Ex-works point upon request.

THERE ARE NO WARRANTIES, EXPRESSED, IMPLIED OR STATUTORY WHICH EXTEND BEYOND THE DESCRIPTION ON THE FACE HEREOF, INCLUDING WITHOUT LIMITATION, THE IMPLIED WARRANTIES OF MERCHANTABILITY AND FITNESS OF PURPOSE.

After Buyer's submission of a claim as provided above and its approval, Seller shall at its option either repair or replace its product, part, or work at the original Ex-works point of shipment, or refund an equitable portion of the purchase price.

The products and parts sold hereunder are not warranted for operation with erosive or corrosive material or those which may lead to build up of material within the product supplied, nor those which are incompatible with the materials of construction. The Buyer shall have no claim whatsoever and no product or part shall be deemed to be defective by reason of failure to resist erosive or corrosive action nor for problems resulting from build-up of material within the unit nor for problems due to incompatibility with the materials of construction.

Any improper use, operation beyond capacity, substitution of parts not approved by Seller, or any alteration or repair by others in such manner as in Seller's judgment affects the product materially and adversely shall void this warranty.

No employee or representative of Seller other than an Officer of the Company is authorized to change this warranty in any way or grant any other warranty. Any such change by an Officer of the Company must be in writing.

The foregoing is Seller's only obligation and Buyer's only remedy for breach of warranty, and except for gross negligence, willful misconduct and remedies permitted under the General Terms of Sale. In no event shall Buyer be entitled to incidental or consequential damages. Any action for breach of this agreement must commence within one (1) year after the cause of action has occurred.



(800) 471-8769