



Rotary Blowers, Vacuum Pumps And Gas Boosters

The sliding blade design employed in these machines is an efficient and simple method of supplying medium volumes of air and gases at low pressure differentials. The once through lubrication system with isolated bearings makes these ideal for handling aggressive gases including Digester and Landfill.

The cylinder is made from high grade close grained cast iron with deep fins to provide ample cooling surface. The bore is machined to give maximum blade life. SG iron rotor and shaft assembly, balanced and accurately slotted. Sliding blades are made from a non-asbestos hard wearing resin bonded fabric material. Roller bearings are fitted to both ends and isolated from the cylinder.

Mechanical seals are fitted when handling aggressive gases to provide a positive seal. The blade depth can be quickly checked without removal of any parts or pipework.

All machines in this range are aircooled with a fan fitted at the rear end to assist cooling. Overheating of vacuum pumps continuously working at 457 mm Hg (18" Hg) and above is eliminated by the introduction of cool filtered ballast air.

Normally supplied belt driven at speeds to give exact output requirements.

Compliant to : IGE / UP / 2

ATEX DIRECTIVE

MACHINERY DIRECTIVE

L95HP-L320HP

Vacuum Pump:

Liquid Waste Tankers

Air/Gas Compressors:

Digester Gas Mixing

Burners

Gas Engines

Vapour Recovery

Aeration

Crop Spray

- Simple Installation
- Cool Running
- Low Noise Level
- Vibration-Free Running
- Easy Maintenance
- Pulsation-Free Delivery



Dimensions & Performances

L95-175 BLOWERS - Free Air Delivered And Power

Model	Speed	Dis- placement m ³ /hr	0.35 bar		0.70 bar		1.00 bar		1.40 bar		1.75 bar		2.00 bar	
			Air Flow	Power	Air Flow	Power	Air Flow	Power	Air Flow	Power	Air Flow	Power	Air Flow	Power
			m ³ /hr	kW	m ³ /hr	kW	m ³ /hr	kW	m ³ /hr	kW	m ³ /hr	kW	m ³ /hr	kW
L95HP	900	144	122	2.1	111	3.2	101	4.1	89	5.4	78	6.5	70	7.2
	1000	161	136	2.5	125	3.6	117	4.7	104	6.0	94	7.1	86	8.0
	1100	177	148	2.8	137	4.1	128	5.2	115	6.7	105	8.0	97	8.9
	1200	192	161	3.1	151	4.6	141	5.8	129	7.5	119	9.0	111	10.0
L130HP	900	197	171	3.0	159	4.5	149	5.7	136	7.4	124	8.8	116	9.9
	1000	221	190	3.4	179	5.1	170	6.4	158	8.3	147	9.9	139	11.1
	1100	243	208	3.8	197	5.7	188	7.2	176	9.3	165	11.1	158	12.5
	1200	265	226	4.3	215	6.3	207	8.9	195	10.1	184	12.0	177	13.4
L175HP	900	267	234	4.1	223	6.0	213	7.7	201	9.8	189	11.7	181	13.0
	1000	297	261	4.6	252	6.7	244	8.5	233	10.9	223	13.0	217	14.5
	1100	326	284	5.2	276	7.6	268	9.7	259	12.5	250	14.9	244	16.6
	1200	355	309	6.0	300	8.6	294	10.8	285	13.8	277	16.3	271	18.2

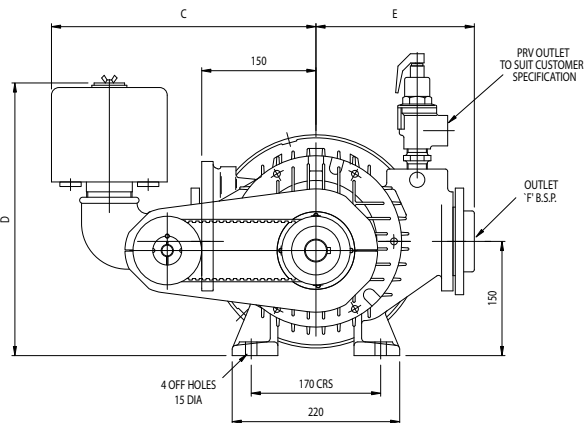
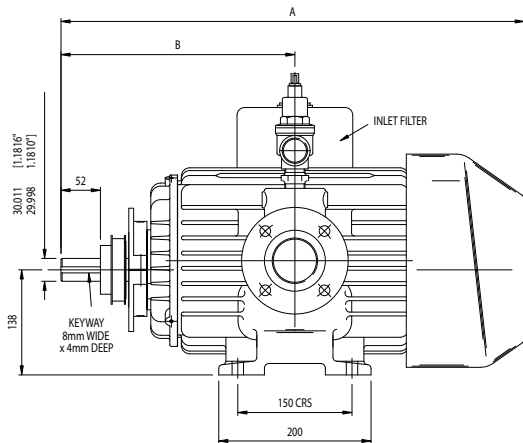

Model	L95	L130	L175
A	528	628	710
B	267	307	359
C	347	347	355
D	358	358	385
E	208	208	212
F	2"	2"	2 1/2"
KGS	101	119	139

L240-320 BLOWERS - Free Air Delivered And Power

Model	Speed	Dis- placement m ³ /hr	0.35 bar		0.70 bar		1.00 bar		1.40 bar		1.75 bar		2.00 bar	
			Air Flow	Power	Air Flow	Power	Air Flow	Power	Air Flow	Power	Air Flow	Power	Air Flow	Power
			m ³ /hr	kW	m ³ /hr	kW	m ³ /hr	kW	m ³ /hr	kW	m ³ /hr	kW	m ³ /hr	kW
L240HP	650	367	329	6.7	318	8.9	308	10.8	296	13.2	284	15.4	276	16.9
	700	396	353	7.5	342	9.8	333	11.8	320	14.4	309	16.7	302	18.4
	750	425	378	8.1	367	10.5	358	12.5	346	15.5	335	17.6	328	19.3
	800	453	402	8.8	392	11.3	383	13.5	371	16.7	360	19.0	354	20.8
	850	482	424	9.6	415	12.2	407	14.6	397	17.8	388	20.4	382	22.3
L320HP	650	491	442	10.0	431	12.7	421	14.9	409	18.0	397	20.6	389	22.5
	700	528	475	11.0	464	13.8	455	16.1	443	19.3	432	22.0	424	24.0
	750	565	508	12.0	497	14.9	488	17.5	476	20.9	465	23.8	457	25.9
	800	604	540	13.1	530	16.2	521	18.9	509	22.5	498	25.7	491	27.9
	850	642	569	14.2	559	17.5	550	20.4	541	24.2	532	27.5	525	29.9

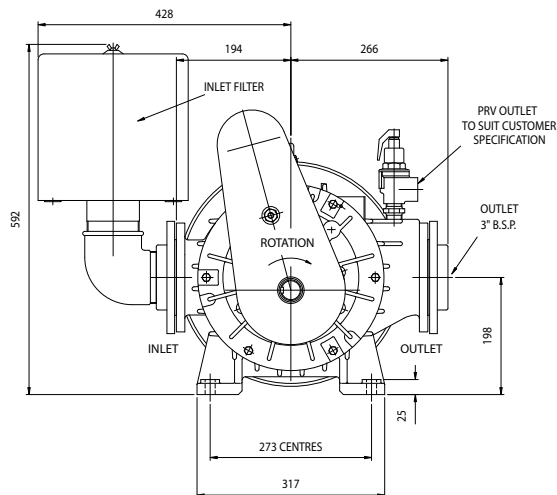
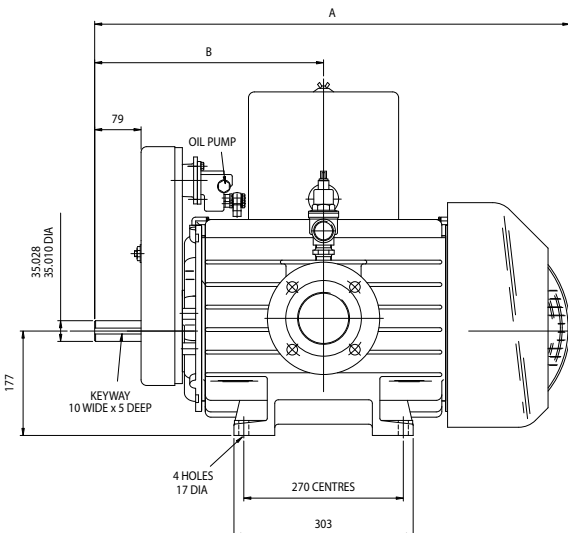

Model	L240	L320
A	702	804
B	336	387
KGS	202	240

L95-175 VACUUM PUMPS - Capacity (Volume At Suction Conditions) And Power

Model	Speed	Displacement m ³ /hr	254 mmHg		381 mmHg		508 mmHg		559 mmHg	
			Air Flow m ³ /hr	Power kW	Air Flow m ³ /hr	Power kW	Air Flow m ³ /hr	Power kW	Air Flow m ³ /hr	Power kW
L95HP	900	144	119	2.0	110	2.4	96	2.8	88	3.0
	1000	161	134	2.3	126	2.8	111	3.2	103	3.4
	1100	177	149	2.5	141	3.1	127	3.5	118	3.7
	1200	192	164	2.8	157	3.4	145	3.9	135	4.1
L130HP	900	197	166	2.8	158	3.4	146	4.0	137	4.2
	1000	221	187	3.1	180	3.8	167	4.5	158	4.7
	1100	243	208	3.5	202	4.3	189	5.0	180	5.2
	1200	265	230	3.9	223	4.7	212	5.5	204	5.7
L175HP	900	267	232	3.7	223	4.4	208	5.2	199	5.5
	1000	297	260	4.2	251	5	236	5.8	226	6.1
	1100	326	285	4.7	279	5.7	265	6.6	256	6.9
	1200	355	312	5.4	307	6.3	294	7.3	284	7.7

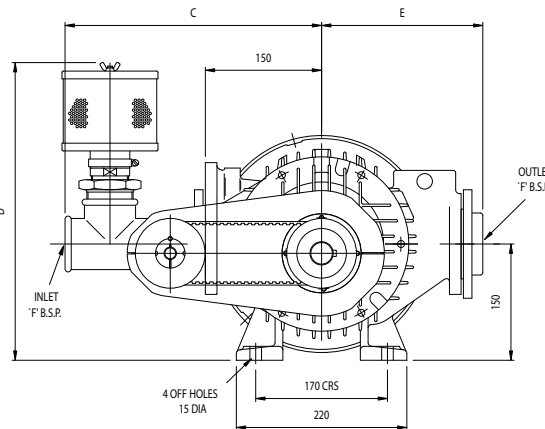
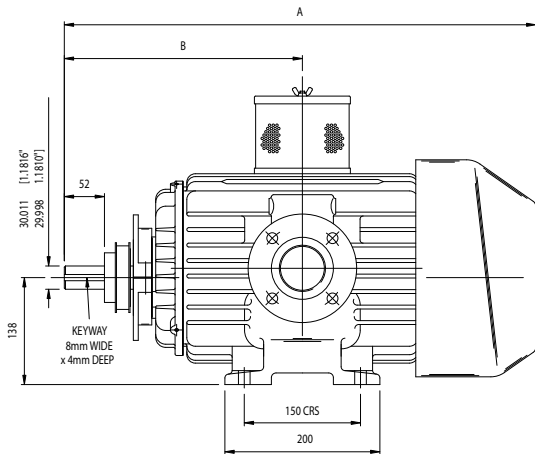

Model	L95	L130	L175
A	528	628	710
B	267	307	359
C	347	347	355
D	358	358	385
E	208	208	212
F	2"	2"	2 1/2"
KGS	101	119	139

L240-320 VACUUM PUMPS - Capacity (Volume At Suction Conditions) And Power

Model	Speed	Displacement m ³ /hr	254 mmHg		381 mmHg		508 mmHg		559 mmHg	
			Air Flow m ³ /hr	Power kW	Air Flow m ³ /hr	Power kW	Air Flow m ³ /hr	Power kW	Air Flow m ³ /hr	Power kW
L240HP	650	367	323	5.5	312	5.9	287	7.4	267	7.7
	700	396	346	6.1	335	6.5	311	8.0	292	8.2
	750	425	373	6.6	361	7.1	338	8.6	321	8.9
	800	453	398	7.2	387	7.7	363	9.3	348	9.5
	850	482	419	7.8	409	8.3	388	9.9	375	10.2
L320HP	650	491	441	8.2	429	8.5	404	9.7	380	9.9
	700	528	472	9.0	460	9.3	435	10.4	413	10.7
	750	565	505	9.8	494	10.2	470	11.2	452	11.5
	800	604	538	10.7	529	11.0	508	12.1	489	12.3
	850	642	565	11.5	557	11.8	539	12.9	526	13.1

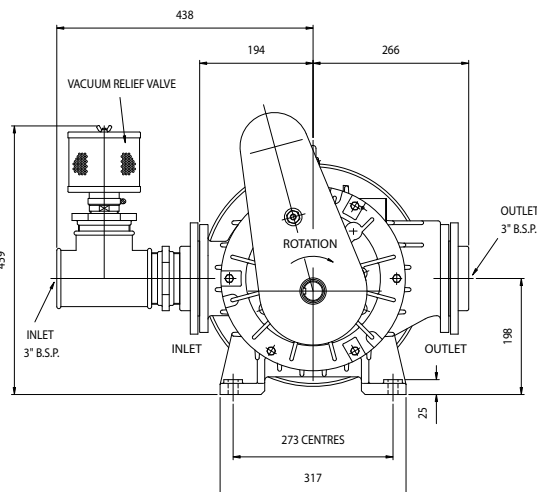
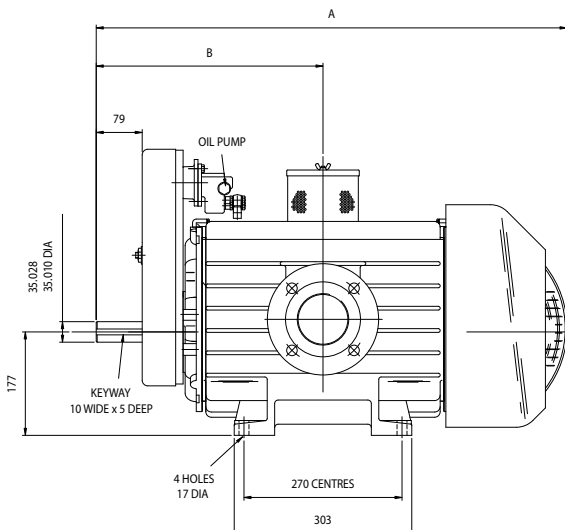

Model	L240	L320
A	702	804
B	336	387
KGS	191	225

Whilst the details contained in this leaflet are representative of the machines, the actual products may differ from the illustrations due to improvements in design. Certified copies and performance curves will be supplied on request.

The Utile Engineering Co. Ltd. Irthlingborough, Northamptonshire. NN9 5UG. England
Tel: +44 (0)1933 650216 Fax: +44 (0)1933 652738 E-mail: sales@utileengineering.com

www.utileengineering.com