

Combat[®]

Compact Tubular Unit Heaters

**Over
91.5%^{NET}
Efficient!**



- Compact size - ideal when space is at a premium
- For room sealed or open flued installation
- Models meet ECA efficiency requirements
- Automatic ignition burners with remote lockout and reset
- Horizontal and vertical air distribution
- Light to indicate lockout
- Long life provided by aluminised steel heat exchangers
- Suspended, shelf or wall mounted installation frees valuable workspace and provides flexibility
- Remote fan operation for summer air circulation
- Vertical louvres available
- Smaller size - easier to handle and less expensive to ship
- Easy to install, maintain and operate with rear or top air and flue spigots

Quality in Any Language[™]



Authorised User No. 00184



0063

Technical Data - Standard CTCU Range

Model		7	11	15	22	27	32
Heat Input - Gross	[kW]	8.5	13.4	18.3	27.5	33	38.5
	[Btu/h] x [1000]	29	46	62	94	113	131
Heat Input - Net	[kW]	7.7	12.1	16.5	24.8	29.7	34.7
	[Btu/h] x [1000]	26	41	56	85	101	118
Heat Output	[kW]	7.1	11.1	15.1	23	27.2	31.7
	[Btu/h] x [1000]	24	38	52	78	93	108
Gas Rate Natural (G20)	[m ³ /h]	0.8	1.3	1.7	2.6	3.1	3.7
	[ft ³ /h]	29	45	62	93	109	131
Gas Rate Natural (G25)	[m ³ /h]	0.9	1.5	2.0	3.0	3.7	4.3
Gas Rate LPG Propane (G31)	[m ³ /h] [kg/h]*	0.3 0.16	0.5 0.25	0.7 0.34	1.0 0.51	1.2 0.60	1.5 0.73
Gas Rate LPG Butane (G30)	[m ³ /h] [kg/h]*	0.2 0.09	0.4 0.14	0.5 0.19	0.8 0.29	1.0 0.37	1.1 0.41
Gas Connection		R - ½"	R - ½"	R - ½"	R - ½"	R - ½"	R - ½"
Number of Burners		2	3	4	5	6	7
Inlet Pressure	[mbar]	17 Minimum, 50 Maximum 25 Minimum, 50 Maximum 30 Minimum, 50 Maximum					
Natural Gas	[G20] [G25]						
LPG Butane	[G30]						
LPG Propane	[G31]						
Electrical Supply		230 V, 50 Hz, 1 Ø					

* For litres per hour, multiply: (kg/h) x 1.97

Air Handling Data - CTCUA Range

CTCUA heaters are fitted with axial fan systems, consisting of a low noise fan(s) powered by a direct drive motor located on the rear of the unit. CTCUA heaters should be used for free blowing applications only.

Model		7	11	15	22	27/32
Air Flow	[m ³ /h]	1120	1220	2710	2750	4474
Air Throw	[m]	9	12	14	16	21
Running Current	[A]	1.1	1.2	1.5	1.7	1.5
Start Current	[A]	1.7	1.8	2.5	2.9	2.6
Total Electrical Load	[W]	260	274	336	384	345
Noise @ 3 m (determined by EN ISO 3746 parallel piped measurement surface)						
dB[A]	[NR]	37 [31]	41 [35]	45 [39]	48 [42]	48 [42]

Technical Flue Data - Standard CTCU Range

CTCU heaters must be fitted with a flue system. Straight lengths and bends can be added, if required. For every additional 90° bend added to the flue, the maximum flue length must be reduced by 1 m [0.5 m for CTCU 7 and 11].

NOTE: The flue terminal must not be positioned under a window or anywhere that could draw combustion products back into the building.

Each joint in the flue must be made using the manufactured female joint with the special seal.

Open Flue and Room Sealed Arrangements

Model		7	11	15	22	27/32
Maximum Length	[m]	2.5	4	5	5	5
Flue and Intake Size Ø	[mm]	80	80	80	80	100

Dimension Data - CTCUA Range (All Models)

Model		7	11	15	22	27/32
'A' Height	[mm]	304	304	450	450	578
'B' Mounting Hole Spacing	[mm]	239	239	385	385	513
'C' Centre of Flue [Top Option]	[mm]	151	151	151	172	146
'D' Centre of Flue	[mm]	68	68	68	46	25
Weight	[kg]	28	30.5	38.5	41	52.3
Mounting Height to Heater Base	[m]	Minimum 1.8 Maximum Recommended 3.5 Heaters may be mounted at a higher level if destratification fans and/or turn down nozzles are installed.				

Heater Clearances to Combustibles (mm)

Above Heater	Below Heater	To Side of Heater	To Rear of Heater	To Front of Heater	To Flue
150	300	100	250	3000	50

CTCUA Specifications - (All Models)

All dimensions shown in mm.

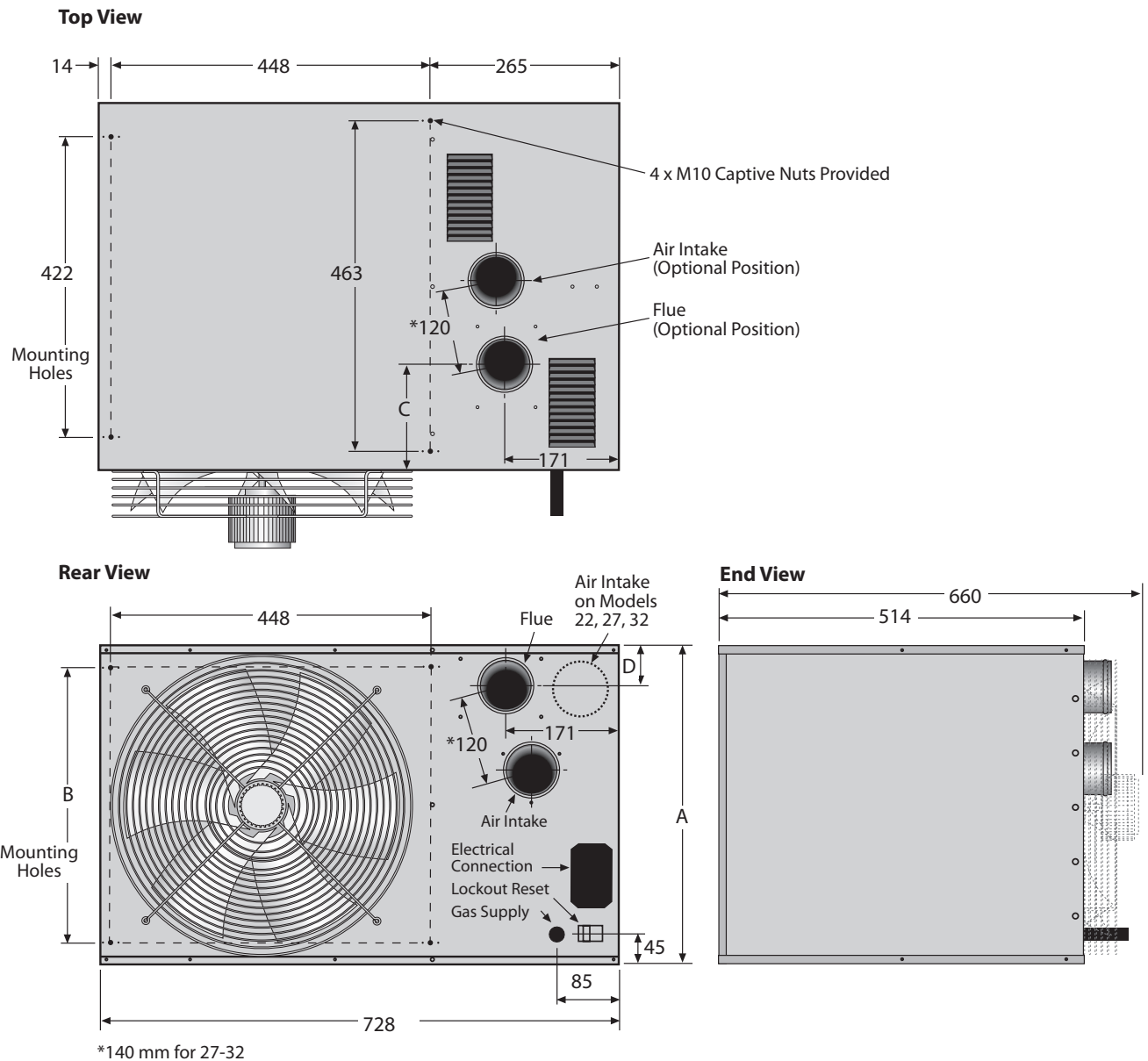

Specifications - Open Flue Arrangement (All Models)

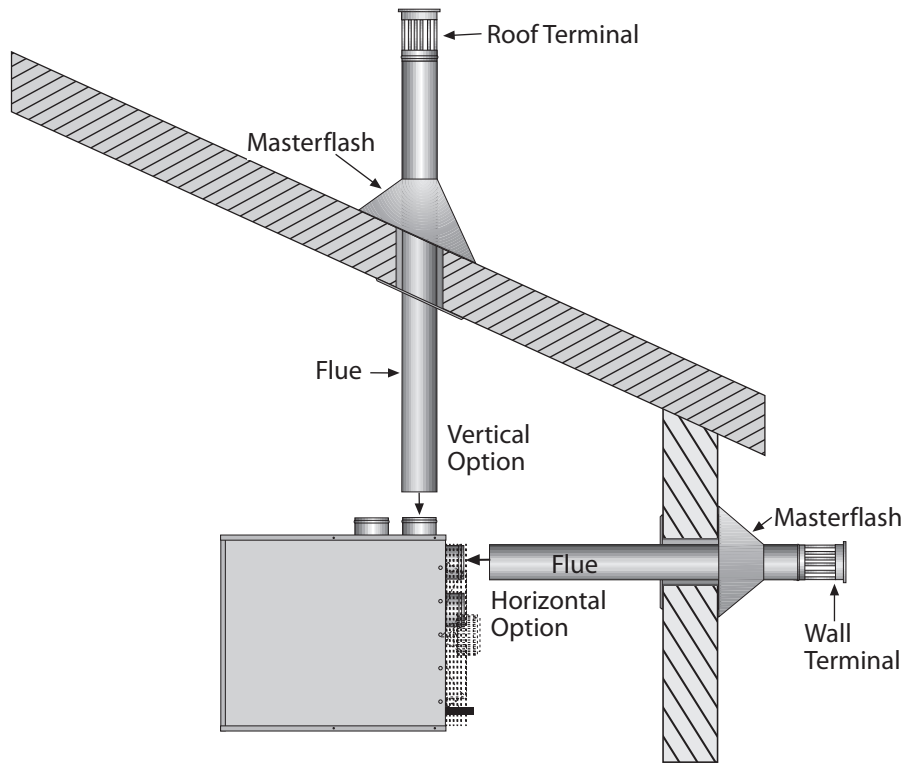

Specifications - Room Sealed Flue Arrangement (All Models)

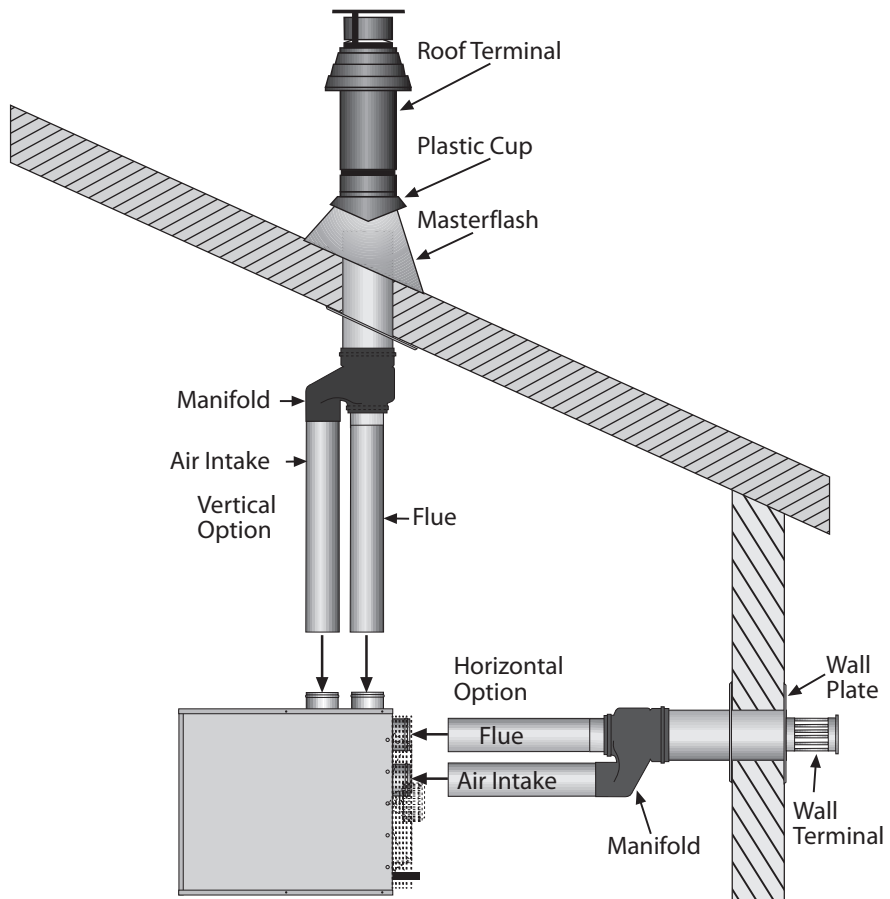

Ignition Systems

CTCU heaters are automatic ignition burners.

Burner Options

CTCU heaters are fitted with On/Off burners as standard.

Air Outlets

CTCU heaters are fitted with adjustable horizontal louvres as standard. Optional vertical air discharge is available. For additional information, please consult the CTCU heater price list or the Installation, Commissioning, Operation and Service Manual.

Advice should be sought from Roberts-Gordon to ensure that proposed ducting systems are compatible with the heater.



Authorised User No. 00184

COMBAT[®] Compact Tubular Unit Heaters are high efficiency heaters and are listed on the Enhanced Capital Allowance Scheme 'Energy Technology Product List'.

The ETL symbol is a UK registered certification mark of the Carbon Trust.

Important Notice

The equipment described in this Data Sheet is suitable for most commercial and industrial heating applications. However, in certain environments, particularly where there is a chlorinated atmosphere (e.g. near degreasing plant or other solvent processes), or a particularly dusty atmosphere, specialist advice should be sought at the design stage. Please consult Roberts-Gordon.

Roberts-Gordon reserves the right to alter product specification details without notice.

Installation Code and Annual Inspections:

All installation and service of ROBERTS GORDON[®] equipment must be performed by a contractor qualified in the installation and service of equipment sold and supplied by Roberts-Gordon and conform to all requirements set forth in the ROBERTS GORDON[®] manuals and all applicable governmental authorities pertaining to the installation, service and operation of the equipment. To help facilitate optimum performance and safety, Roberts-Gordon recommends that a qualified contractor conduct, at a minimum, annual inspections of your ROBERTS GORDON[®] equipment and perform service where necessary, using only replacement parts sold and supplied by Roberts-Gordon.

Further Information: Applications, engineering and detailed guidance on systems design, installation and equipment performance is available through ROBERTS GORDON[®] representatives. Please contact us for any further information you may require, including the Installation, Commissioning, Operation and Service Manual.

This product is not for residential use.

This document is intended to assist licensed professionals in the exercise of their professional judgment.

Roberts-Gordon Europe Limited

Unit A, Kings Hill Business Park
Darlaston Road, Wednesbury
West Midlands, WS10 7SH UK
Telephone: +44 (0)121 506 7700
Fax: +44 (0)121 506 7701
Service Telephone: +44 (0)121 506 7709
Service Fax: +44 (0)121 506 7702
E-mail: uksales@rg-inc.com
E-mail: export@rg-inc.com
www.rg-inc.com